

# Plas Mawr Learning Resource Pack

## Key Stage 2

History: The Tudors



### Introduction

The aim of this pack is to help teachers approach a self-led visit in a creative, confident and imaginative way. The activity suggestions are flexible and can be carried out in a number of ways. We encourage teachers to select and adapt the material to ensure it meets topic and year group needs.

### Booking a visit

Did you know that self-led visits to Cadw sites are free to education groups attending education establishments in the European Union?

To book your free visit, please follow these simple steps:

- Please book your visit at least five working days in advance.
- Telephone the site to check the availability for the date you'd like to visit.
- Once you have agreed a date and time with the site, complete the online booking form at [www.cadw.wales.gov.uk/learning](http://www.cadw.wales.gov.uk/learning)

We also offer interactive, curriculum-linked education activities at selected sites.



### Health and Safety

Teachers and group leaders are responsible for carrying out risk assessments prior to the visit, in accordance with guidance issued by local education authorities. We offer free teacher familiarisation visits to enable teachers to write the risk assessments and plan activities before bringing a group to the site. The learning pages on the Cadw website offer advice for planning your visit and site specific information.





## The Hall

The tour of the house begins in the hall. The hall wasn't the main living room for the family, but a reception for visitors and a servant's dining room.

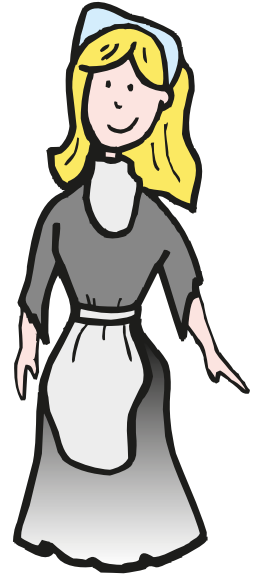

Robert Wynn's coat of arms are shown on the plasterwork above the fireplace.

Can you try and copy the details?

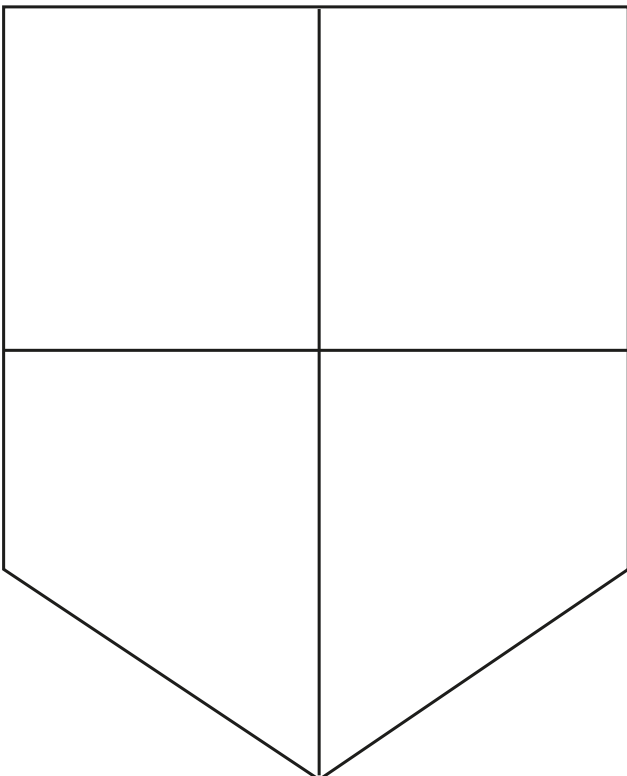

What other objects can you see?	Who might have used them?



### Fill in the missing words:

Robert \_\_\_\_\_ was the third son of John Wynn of Gwydir. When he was a younger man he served as a steward for Sir \_\_\_\_\_ a diplomat. He travelled to the great courts of \_\_\_\_\_. He returned to North Wales in 1555 and married Dorothy \_\_\_\_\_. He began to build Plas Mawr in 1576 and the house was completed in \_\_\_\_\_. When Dorothy died, he remarried to a lady called Dorothy Dymock and they had \_\_\_\_\_ children.

Robert died in 1589 and is buried in a fine tomb at \_\_\_\_\_ church in Conwy.

---

Griffiths	Philip Hoby	seven	1585
Wynn	Europe	St Mary's	



## Chamber over the Parlour

This room is thought to be Dorothy's bedchamber. A bedroom at this period was used not only for sleeping, but as a sitting and dressing room, and even for informal eating.

**“Good night, sleep tight”.** I'm sure you would have heard of this saying before. Ask a teacher or room steward permission to let just one of your group look under the mattress. Let them tell you what they saw and answer this question:

**Why did you need to “sleep tight?”**



In this room, there are lots of objects that would help Dorothy to keep warm. Can you find just two, sketch them and tell me what you think they were called?

**Object 1**

**Object 2**

What do you think the large hanging box is for?



## The Kitchen

The kitchen has been set up as it would have been when it was in use in Tudor times, and one has the feeling that the staff have just popped out and will be coming back any minute.

Can you name five types of food found on the table?

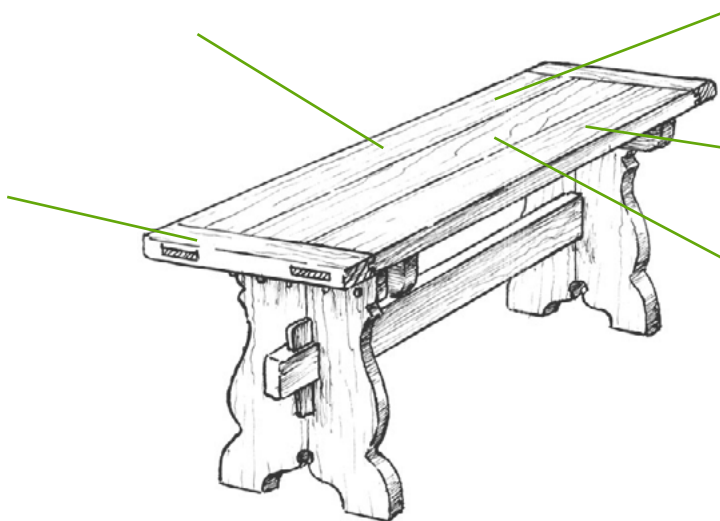

Can you complete the picture?

How do you think they cooked the food?

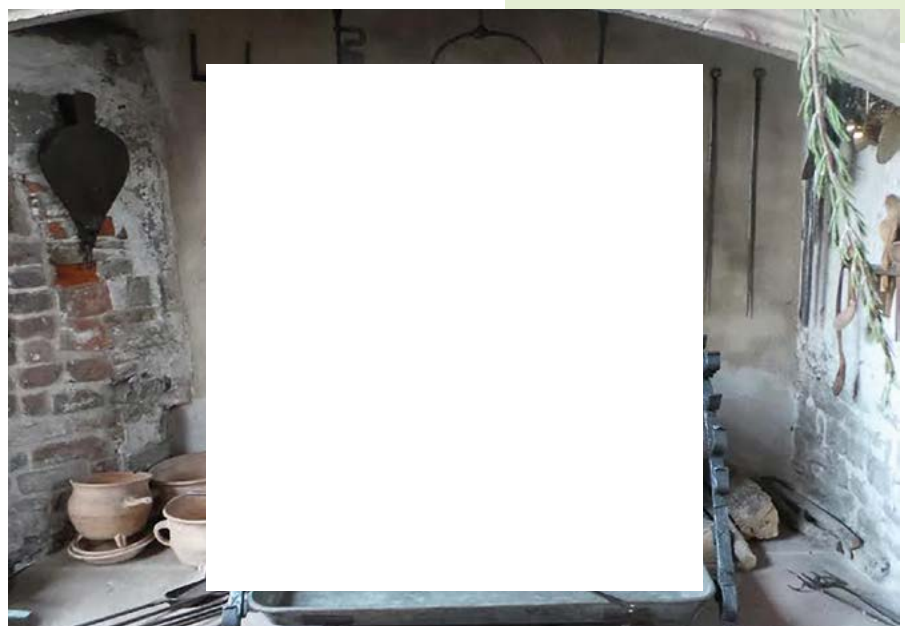



## The Great Chamber

This room is known as the Great Chamber. This is the room where Robert would have entertained his important guests.

This room has the most elaborate plasterwork.

Can you choose your favourite plaster circle and copy the design?

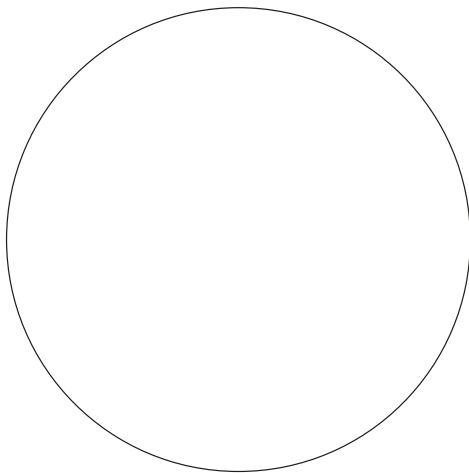

Go to the top table. Can you draw in the rectangle below just some of the items Robert and his family would have used during their meal?

It was very important to Robert to show his guests how much he respected Queen Elizabeth. Above the fireplace there are three pieces of plasterwork which show this.

Can you write down what they are?

1. \_\_\_\_\_
2. \_\_\_\_\_
3. \_\_\_\_\_

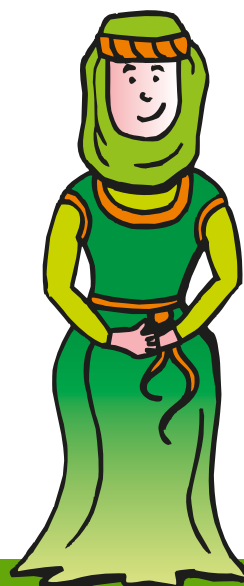

Did you know that forks didn't arrive in the UK until 1620! Also the gentry ate with their gloves on!

Use this page to write down or sketch anything else of interest.